

Pediatric Scale

Model SR635i

The SR635i Pediatric Scale provides reliable and accurate weight data for infants up to 20 Kilograms. The large, durable contoured weighing platform provides a safe and comfortable base for infants and toddlers. The easy-to-read 16 character LCD can display weight information in any of four modes:

Pounds/Ounces	1/4 oz increments
Pounds Decimal	0.01 pound increments
Kilograms	0.005 kilo increments
Grams	5 gram increments

The integrated, smooth-gliding cart provides quiet movement of the scale and features two storage shelves.



ANTIMICROBIAL

SR Scales exclusive: contains Microban[®] antimicrobial technology for powerful, continuous product protection against bacteria.

PORTABLE

Scale can be easily rolled to where the patient is with quiet casters and integrated shelves for added storage. Two locking casters provide cart stability.

MEMORY RECALL

Recalls the last stored weight.

BATTERY OR AC POWERED

6 "D" cell batteries provide approximately 10,000 weigh cycles with programmable Auto Power Down (APD) to conserve power.

ALUMINUM PLATE CONSTRUCTION

Antimicrobial composite shelves and weighing platform are durable, lightweight, and easy-to-clean.

EHR/EMR READY

Serial data output can be used to communicate with electronic health records through send or get commands.

OPTIONAL EQUIPMENT

Thermal printer

Also available in KG-only model



4 YEAR
WARRANTY

Pediatric Scale

Model SR635i



SYSTEM SPECIFICATIONS

MAX WEIGHT	44 Lb / 20 Kg
DISPLAY TYPE	16 Character LCD w/ LED Backlight
DISPLAY RESOLUTION	0.01 Lb, 1/4 oz 0.005 Kg, 5 g
ACCURACY	0.1% +/- 1 digit of displayed resolution
DISPLAY UNITS	Lb / Lb oz / Kg / g
CRADLE SIZE	30" x 12-1/2"
POWER	6 "D" cell alkaline batteries or AC wall adaptor
BATTERY LIFE	10,000 Weigh Cycles (est. based on 30 second on-time)
AUTO POWER DOWN (APD)	Programmable on-time to conserve battery life. A low battery indication will appear when it's time to replace the batteries.
MEMORY	Last stable weight is automatically stored in memory. Press RECALL to retrieve.
SERIAL DATA OUTPUT (EHR)	9-pin serial data output can be used to send weight data to optional printer or EHR/EMR systems.
ANTIMICROBIAL	See www.mircroban.com/sr-scales for specifications on Microban [®] technology
WARRANTY	4 years

ACCESSORIES AND OPTIONS

DESCRIPTION	PART NUMBER
KILOGRAM ONLY SCALE	SR635i-KG
PRINTER KIT Includes FRAP1300, FRTP130012C, FRBC1300, FRAP1300-D9, and all mounting hardware	SR8237
REPLACEMENT THERMAL PRINTER	FRAP1300
REPLACEMENT PAPER	FRTP130012C
REPLACEMENT POWER ADAPTOR	FRBC1300
REPLACEMENT DATA CABLE	FRAP1300-D9

DIMENSIONS in [cm]

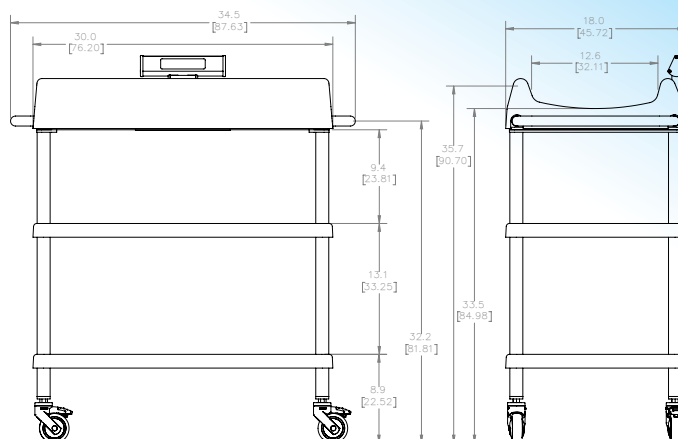

PACKAGING

